



www.johnsonhardware.com

INSTRUCTIONS

1555 CONVERGING DOOR KIT

FOR USE WITH TWO JOHNSON
1500, 1560, 2511, 2710 OR 2711 SERIES
POCKET DOOR FRAMES

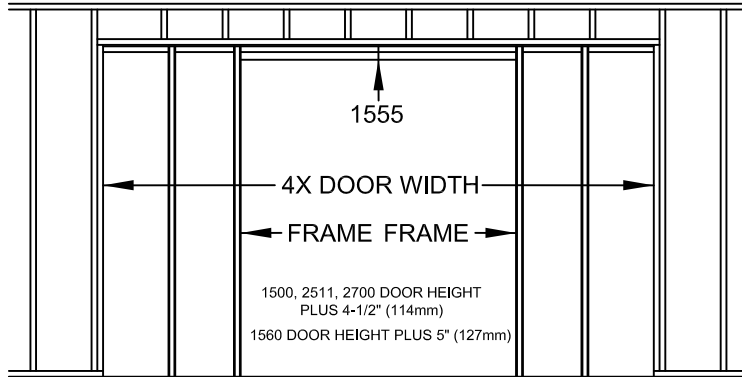

FOR 1500, 1560 AND 2511 SERIES:

ROUGH OPENING WIDTH IS FOUR TIMES DOOR WIDTH

★ **FOR 2710/2711 SERIES:**

ROUGH OPENING IS FOUR TIMES DOOR WIDTH PLUS 1-1/2" (38mm)

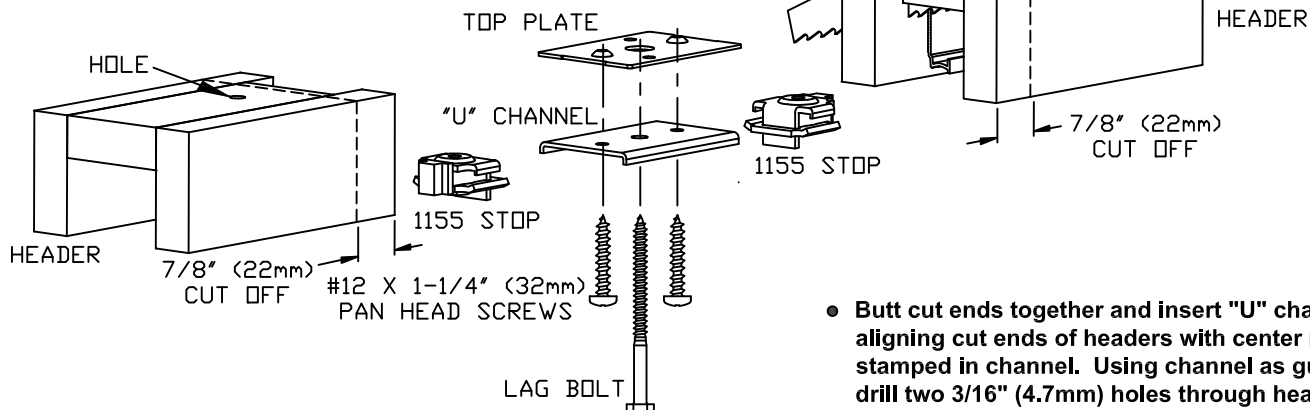
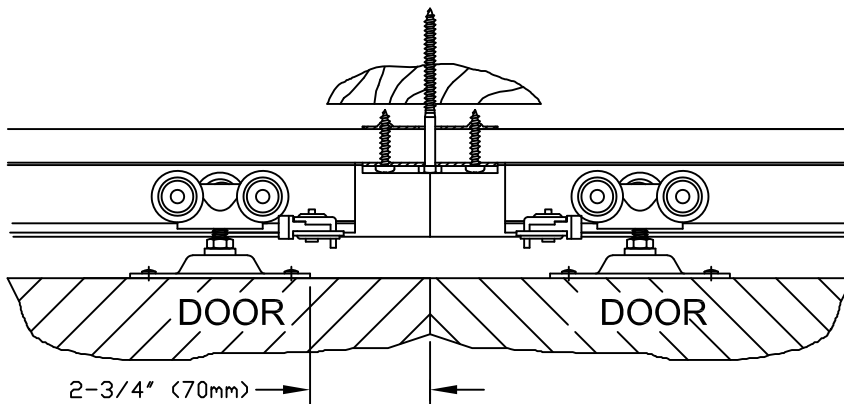
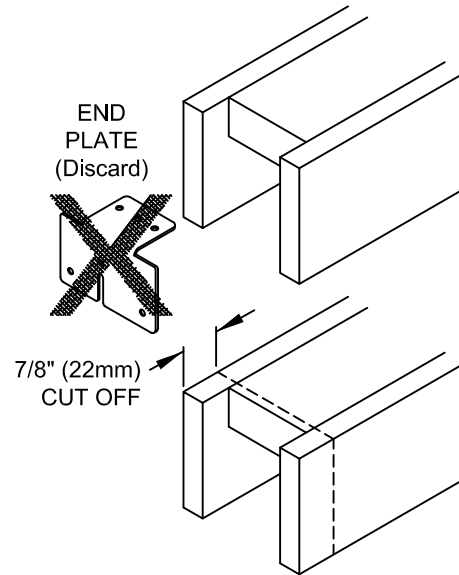

- Butt cut ends together and insert "U" channel, aligning cut ends of headers with center mark stamped in channel. Using channel as guide, drill two 3/16" (4.7mm) holes through headers at outer channel holes. Insert screws through these holes and into top plate on top of header. Tighten, forming a one-piece header.
- Drill a 1/4" (6.3mm) hole at channel center where header ends meet to enable the lag screw to be fastened into rough header for increased center support.
- Insert stops into track and leave loose until doors are hung, then tighten. Proceed with regular frame assembly instructions.

1555PPK3 CONVERGING DOOR KIT

For joining two Johnson 1500, 1560, 2511, 2710 or 2711 Pocket Door Frames

- Remove and discard end plates from "door opening" end of each header.
- Cut 7/8" (22mm) from length of each header (wood part only) where discarded end plates had been located. Cut ends square to keep header straight when joined.

