



INSTRUCTIONS

2050 CONVERGING DOOR KIT

FOR USE WITH TWO JOHNSON 2000 SERIES POCKET DOOR FRAMES

www.johnsonhardware.com

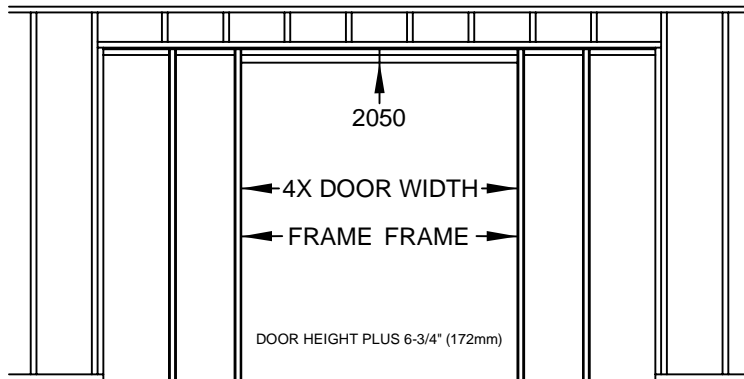

FOR 2000 SERIES:
ROUGH OPENING WIDTH IS FOUR TIMES DOOR WIDTH

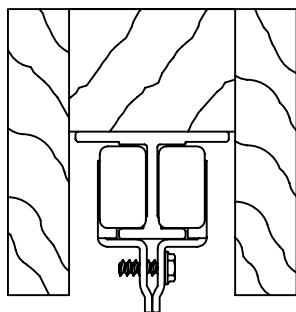
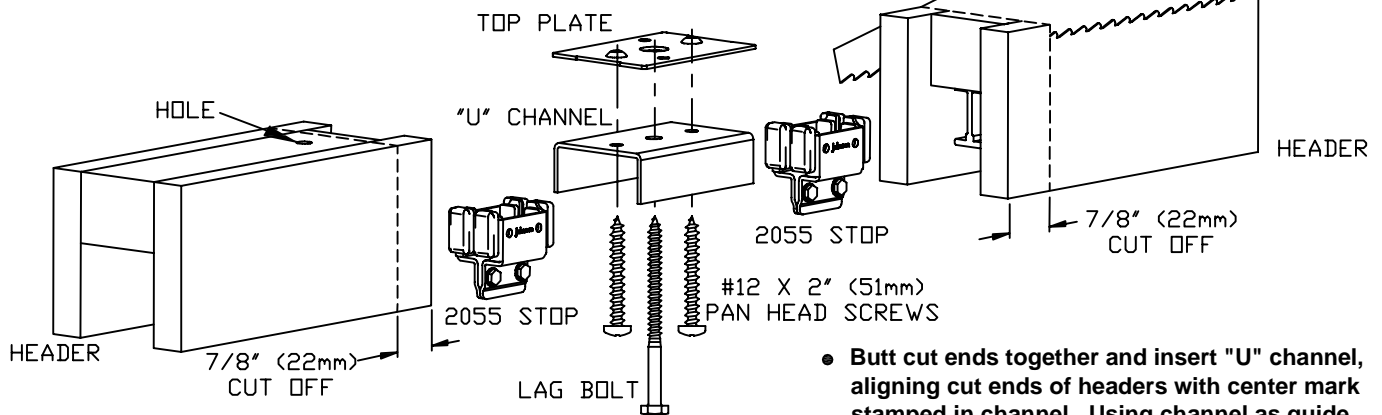
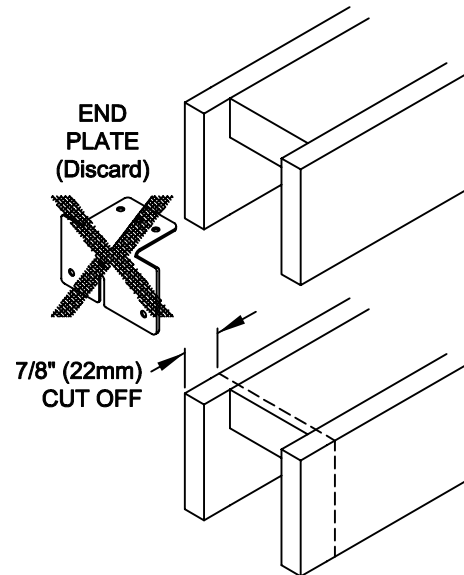
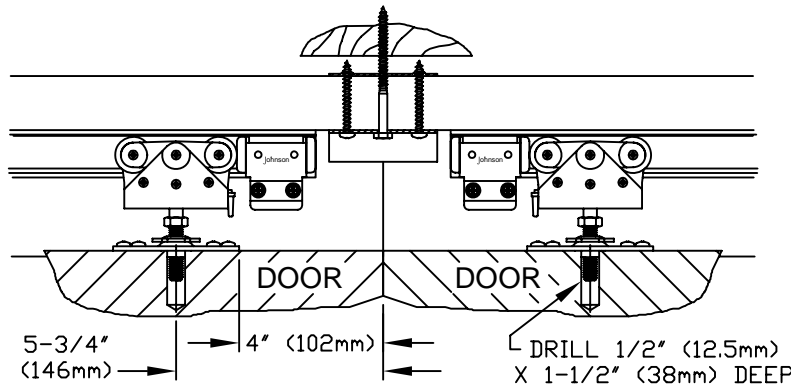

2050 CONVERGING DOOR KIT For joining two Johnson 2000 Pocket Door Frames

- Remove and discard end plates from "door opening" end of each header.
- Cut 7/8" (22mm) from length of each header (wood part only) where discarded end plates had been located. Cut ends square to keep header straight when joined.

- Butt cut ends together and insert "U" channel, aligning cut ends of headers with center mark stamped in channel. Using channel as guide, drill two 3/16" (4.7mm) holes through headers at outer channel holes. Insert screws through these holes and into top plate on top of header. Tighten, forming a one-piece header.
- Drill a 1/4" (6.3mm) hole at channel center where header ends meet to enable the lag screw to be fastened into rough header for increased center support.
- Insert stops into track and leave loose until doors are hung, then tighten. Proceed with regular frame assembly instructions.
- **Mount Door Plates 4" (102mm) from edge of door.**